



## Features:

CAN 2.0B supported

12V or 24V power supply supported

13 power outputs (2 of which supporting PWM mode)

Operating temperature range: -40 to +85°C

Waterproof (IP67)

Replaceable automotive mini blade fuses for overcurrent protection

Cinch connector SHS 18pin

# Contents

Features:	1
1. How to Connect CAN bus:	3
2. Keybox Technical Specifications	3
3. Mechanical dimensions	4
4. Cinch Connector 18 pin:	5
5. Electrical Loads Connection	6
6. Pin Assignment	6
7. Output State Machine Diagram	7
8. Message header description	9
9. General Data Format	9
10. Default Settings	10
11. Set single pin state (01h)	10
12. Set multiple pin state (02h)	11
13. Set PWM state (03h)	12
14. Fault-event message (01h)	13
Configuration commands	14
15. Read Digital Input 8-bit (0Ah)	14
16. Read Fault event (0Bh)	15
17. Get software revision (2Ah)	16
18. Baud rate setting (6Fh)	17
19. Set Source address (70h)	17
20. Periodic fault message transmission (71h)	18
21. Fault-event message transmission (72h)	19
22. Heartbeat TX (75h)	20
23. Heartbeat RX (76h)	21
24. Periodic fault message period (77h)	22
25. Restore default parameters (81h)	22
26. Set CAN protocol	23
27. Keybox fuse map	24
28. Revision history	25

## 1. How to Connect CAN bus:

PIN	FUNCTION
D2	CAN L
E2	CAN H

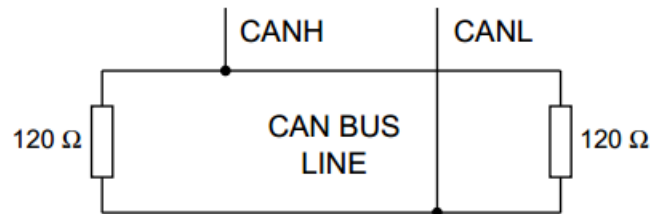

Each end of the CAN bus is terminated with 120Ω resistors in compliance with the standard to minimize signal reflections on the bus. You may need to place a 120Ω terminating resistor between CAN-L and CAN-H

NOTE: the Keybox PCB is set up so that it is possible to require the terminating resistor to be built in.

## 2. Keybox Technical Specifications

Electrical	Value	Unit
Supply Voltage (Battery Voltage)	9-16 (12V) or 18-31 (24V)	V
Maximum input current	120	A
Maximum current single pin	10 (12V) or 5 (24V)	A
Maximum Digital input voltage	Battery Voltage	V
Digital input low voltage max	5,5	V
Environmental	Value	Unit
Storage temperature range	-40 to +85	°C
Operating temperature range	-40 to +85	°C
Humidity	0 to 98	%

### 3. Mechanical dimensions

Dimensions are in inches and [millimeters].

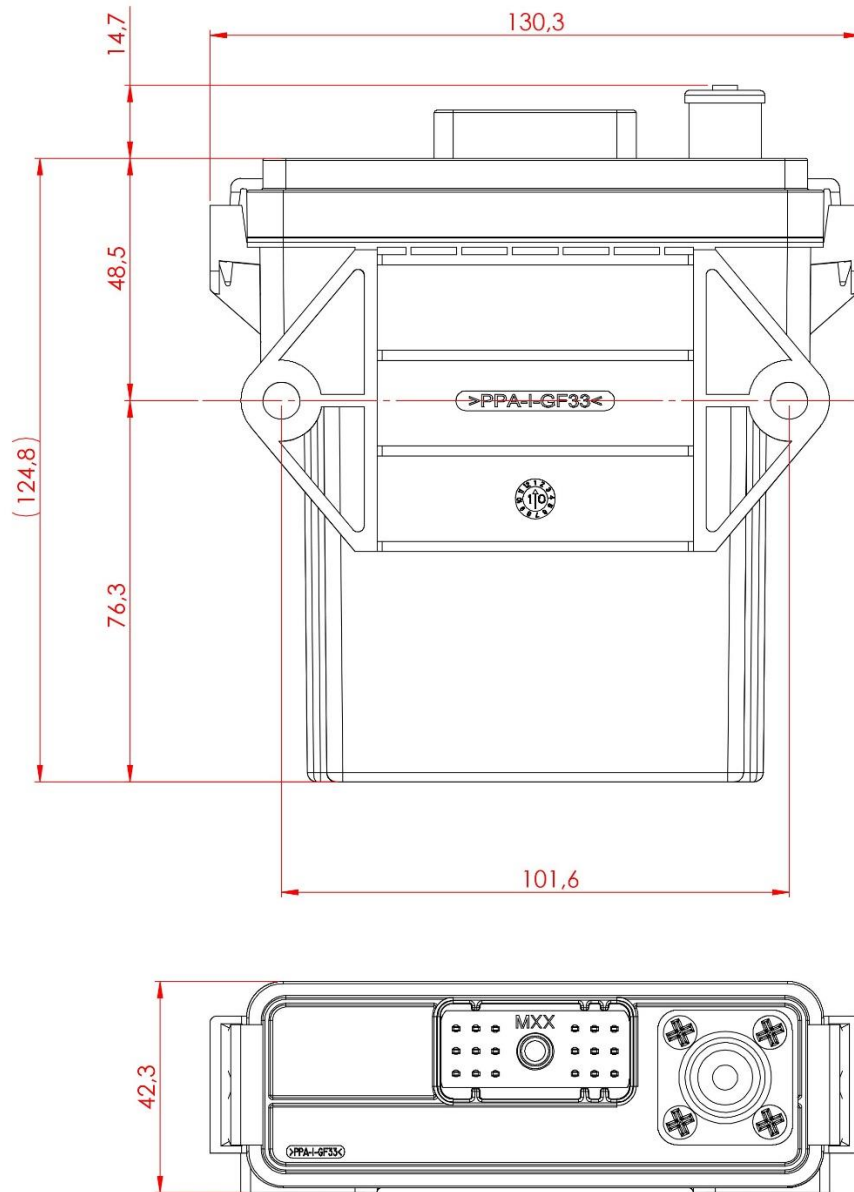

#### 4. Cinch Connector 18 pin:

The 18pin Cinch header connector 5810118038 mates with Cinch harness connector 5810118023:

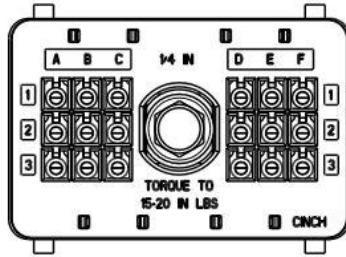

Output	Pin
Ch 6	A1
Ch 9	A2
Ch 10	A3
Ch 5	B1
TXRX-	B2
Ch 1	B3
Ch 4	C1
Ch 12	C2
TXRX+	C3
Ch 13	D1
CANL	D2
GND	D3
Ch 2	E1
CANH	E2
Ch 7	E3
Ch 3	F1
Ch 11	F2
Ch 8	F3

V<sub>BATT</sub> supply connector: Amphenol SLPPA16BSO



## 5. Electrical Loads Connection

The device could be set to control from 1 to 13 outputs. Each output (except for PIN12 and PIN13 driven by a double channel Mosfet) is a contact of an on/off relay, open or closed to Vbatt. The relay of the output contacts Ch2 and Ch5 could be set to work as open or close to ground contacts. Depending on the requested application the number of relays mounted in the PCB can be customized in the range of 1 to 11. For the 12V version, the relays can be customized to operate at 10A or 5A max current.

The electrical load is connected between an output pin of the Keybox and ground, and it is ON when the corresponding pin state is HIGH.

If the contacts Ch2 and Ch5 are set as Low Side driver, the electrical load is connected between Vbatt and the output pin of the Keybox, and it is ON when the corresponding pin state is HIGH.

The output pin state can be HIGH (relay contacts shorted) or OFF (pin floating, relay contacts open).

The ground can be connected either to the ground pin of the Keybox or directly to the battery's negative pole. An automotive mini blade fuse protects the circuit. The fuse rate is set according to the customer needs from 1 to 10Amps. The fuses are mounted on fuse holders in order to be easily replaced.

## 6. Pin Assignment

Pin	Output	Function	Fuse Rating	Mosfet	Optional Low Side	Level Sense
A1	Ch6	O	FH6 max 10A			X
A2	Ch9	O	FH9 max 10A			X
A3	Ch10	O	FH10 max 10A			X
B1	Ch5	O	FH5 max 10A		X	X
B2	BUS	TXRX-	NA			
B3	Ch1	O	FH1 max 10A			X
C1	Ch4	O	FH4 max 10A			X
C2	Ch12	O	FH12 max 3A	X		X
C3	BUS	TXRX+	NA			
D1	Ch13	O	FH13 max 3A	X		X
D2	BUS	CANL	NA			
D3	Power	GND	NA			
E1	Ch2	O	FH2 max 10A		X	X
E2	BUS	CANH	NA			
E3	Ch7	O	FH7 max 10A			X
F1	Ch3	O	FH3 max 10A			X
F2	Ch11	O	FH11 max 10A			X
F3	Ch8	O	FH8 max 10A			X

## Function Summary

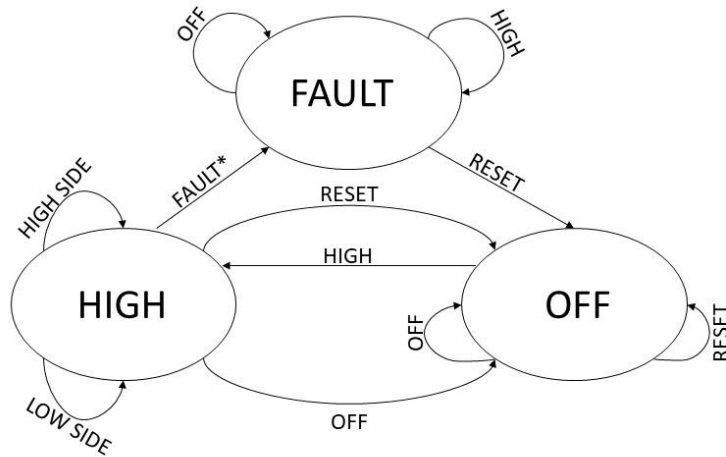

- **O**: Output high side pin
- **TXRX+, TXRX-**: RS485 bus signals
- **GND**: Internally connected to Negative terminal of the batteries
- **CAN-L, CAN-H**: CAN bus signals

## 7. Output State Machine Diagram

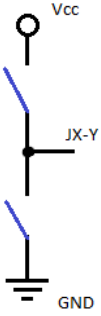

\*= If the output command is Low Side, the fault state is not detected.

The output pin can be in one of the 3 following states:

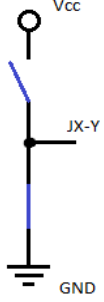
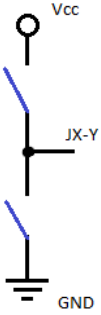
Output state	Pin voltage	Equivalent Circuit
OFF	Floating	
HIGH	High Side – Battery Voltage	
	Low Side – GND	
FAULT	Floating	

Each output circuit is protected against short circuits and overcurrent by a fuse: A failure event occurs when the output command is HIGH (High Side) but the fuse is blown and the voltage level of the pin is not at the battery voltage. If the output command is Low Side the fault state is not detected. To recover the pin from the FAULT state, a reset command is needed. The reset command returns the pin to its initial OFF state.



## 8. Message header description

The 29-bit CAN identifier used in J1939 is structured in the following way:

Priority	Reserved	Data Page	PDU Format	PDU Specific	Source Address
3 bits	1 bit	1 bit	8 bits	8 bits	8 bits

The proprietary format used by PC10 is defined as follows:

Priority = **6**.

Reserved = **0**.

Data page = **0**.

PDU Format = EFh (the message is addressable).

PDU Specific = Destination Address.

Parameter Group Number:

**61184** (EF00h) used for command type messages;

**59904** (EA00h) used for request type messages.

An example of CAN identifier of messages sent to the Keybox is 18EF2100h where:

21h is the destination address (Keybox)

00h is the source address.

An example of CAN identifier of messages sent by the Keybox is 18EFFF21h where:

FFh refers to broadcast messages (no specific destination address)

21h is the source address (Keybox).

## 9. General Data Format

The proprietary protocol has defined a general format for the data fields in the PGN 61184. The format consists of:

1 header field (2 bytes)

1 command byte

8 bytes (the remaining field) are defined specifically for each command.

The data length is 8 bytes, unused bits and bytes are set to all 1's (0xFF).

Byte 0	04h
Byte 1	1Bh
Byte 2	Command
Byte 3-7	Data required for each specific command

## 10. Default Settings

Setting	Default status or level	How to change
Baud rate	250kbit/s	<a href="#">Command 6Fh</a>
Source address	21h	<a href="#">Command 70h</a>
Keybox identifier	21h	<a href="#">Command 70h</a>
Periodic fault message transmission	Disabled	<a href="#">Command 71h</a>
Fault-event message transmission	Enabled	<a href="#">Command 72h</a>
Heartbeat TX	Disabled	<a href="#">Command 75h</a>
Heartbeat RX	Disabled	<a href="#">Command 76h</a>
Periodic fault message period	1s	<a href="#">Command 77h</a>
Restore default parameters	-	<a href="#">Command 81h</a>

## 11. Set single pin state (01h)

This message is sent to the Keybox to set or reset the state of each output pin.

Byte 0	04h	Header bytes
Byte 1	1Bh	
Byte 2	01h	
Byte 3	XXh	Single contact output message XX: pin number 01h: P1 02h: P2 03h: P3 04h: P4 05h: P5 06h: P6 07h: P7 08h: P8 09h: P9 0Ah: P10 0Bh: P11 0Ch: P12 0Dh: P13
Byte 4	YYh	YY: state 00h: OFF 01h: HIGH 02h: RESET
Byte 5,6,7	FFh	Not used

Examples:

Direction	Identifier	Format	Message	Data
To Keybox	18EF2100h	Ext	04 1B 01 01 01 FF FF FF	PIN 1 HIGH
To Keybox	18EF2100h	Ext	04 1B 01 01 00 FF FF FF	PIN 1 OFF
To Keybox	18EF2100h	Ext	04 1B 01 06 01 FF FF FF	PIN 6 HIGH
To Keybox	18EF2100h	Ext	04 1B 01 06 00 FF FF FF	PIN 6 OFF
To Keybox	18EF2100h	Ext	04 1B 01 03 01 FF FF FF	PIN 3 HIGH
To Keybox	18EF2100h	Ext	04 1B 01 03 00 FF FF FF	PIN 3 OFF
To Keybox	18EF2100h	Ext	04 1B 01 0A 02 FF FF FF	RESET PIN 10
To Keybox	18EF2100h	Ext	04 1B 01 05 01 FF FF FF	PIN 5 HIGH
To Keybox	18EF2100h	Ext	04 1B 01 05 00 FF FF FF	PIN 5 OFF
To Keybox	18EF2100h	Ext	04 1B 01 0D 01 FF FF FF	PIN 13 HIGH
To Keybox	18EF2100h	Ext	04 1B 01 0D 02 FF FF FF	RESET PIN 13

## 12. Set multiple pin state (02h)

This message is sent to the Keybox to set the state HIGH or OFF of one or more output pins at the same time.

Byte 0	04h	Header bytes
Byte 1	1Bh	
Byte 2	02h	Set multiple pin state
Byte 3	P8 P7 P6 P5 P4 P3 P2 P1	'1'= set HIGH; '0'= set OFF
Byte 4	0 0 0 P13 P12 P11 P10 P9	'1'= set HIGH; '0'= set OFF
Byte 5,6,7	FFh	Not used

Examples:

Direction	Identifier	Format	Message	Data
To Keybox	18EF2100h	Ext	04 1B 02 01 00 FF FF FF	Set PIN 1 HIGH. All the other outputs OFF
To Keybox	18EF2100h	Ext	04 1B 02 F0 03 FF FF FF	Set PIN from 5 to 10 HIGH; all the other outputs OFF
To Keybox	18EF2100h	Ext	04 1B 02 0F 00 FF FF FF	Set PIN from 9 to 12 HIGH; all the other outputs OFF

### 13. Set PWM state (03h)

This command enables the PWM state on the outputs (PIN12 and PIN13) supporting this feature.

NOTE: If this feature is enabled when the outputs are already HIGH, the previous command is overwritten.

NOTE 2: the PWM state is applicable to a single or both pins with a signal whose frequency is equal to 1kHz.

NOTE 3: the PWM state must be used as dimmer feature (e.g.: lights) only; not recommended for purely inductive loads (e.g.: motor, extractor fan)!

NOTE 4: mind if a fault state occurs on the outputs 12 and/or 13 during the PWM mode, the corresponding fault message will not be transmitted.

Byte 0	04h	Header bytes
Byte 1	1Bh	
Byte 2	03h	PWM state message
Byte 3	XXh	Duty cycle level (D) of PIN12 00h-FFh → 0%-100%
Byte 4	YYh	Duty cycle level (D) of PIN 13 00h-FFh → 0%-100%
Byte 5,7	FFh	Not used

Examples:

Direction	Identifier	Format	Message	Data
To Keybox	18EF2100h	Ext	04 1B 03 80 00 FF FF FF	Set PWM on PIN 12 with D=50%
To Keybox	18EF2100h	Ext	04 1B 03 00 1A FF FF FF	Set PWM on PIN 13 with D=10%
To Keybox	18EF2100h	Ext	04 1B 03 33 33 FF FF FF	Set PWM on both PINs with D=20%
To Keybox	18EF2100h	Ext	04 1B 03 66 00 FF FF FF	Set PWM on PIN 12 with D=40%
To Keybox	18EF2100h	Ext	04 1B 03 00 CC FF FF FF	Set PWM on PIN 13 with D=80%
To Keybox	18EF2100h	Ext	04 1B 03 99 99 FF FF FF	Set PWM on both PINs with D=60%
To Keybox	18EF2100h	Ext	04 1B 03 4D 00 FF FF FF	Set PWM on PIN 12 with D=30%
To Keybox	18EF2100h	Ext	04 1B 03 00 B3 FF FF FF	Set PWM on PIN 13 with D=70%
To Keybox	18EF2100h	Ext	04 1B 03 E6 E6 FF FF FF	Set PWM on both PINs with D=90%
To Keybox	18EF2100h	Ext	04 1B 03 FF 00 FF FF FF	Set PWM on PIN 12 with D=100%

## 14. Fault-event message (01h)

This message is sent by the Keybox when a blown fuse is detected.

Note: it might be transmitted more than one message if other fuses were blown before this event.

Byte 0	04h	Header bytes
Byte 1	1Bh	
Byte 2	01h	Fault message
Byte 3	XXh	XX: pin number 01h: PIN 1 02h: PIN 2 03h: PIN 3 04h: PIN 4 05h: PIN 5 06h: PIN 6 07h: PIN 7 08h: PIN 8 09h: PIN 9 0Ah: PIN 10 0Bh: PIN 11 0Ch: PIN 12 0Dh: PIN 13
Byte 4	01h	Fault condition detected
Byte 5	YYh	Keybox identifier (21h default)
Byte 6,7	FFh	Not used

Examples:

Direction	Identifier	Format	Message	Data
From Keybox	18EFFF21h	Ext	04 1B 01 01 01 21 FF FF	PIN 1 fault state
From Keybox	18EFFF21h	Ext	04 1B 01 02 01 21 FF FF	PIN 2 fault state
From Keybox	18EFFF21h	Ext	04 1B 01 03 01 21 FF FF	PIN 3 fault state
From Keybox	18EFFF21h	Ext	04 1B 01 04 01 21 FF FF	PIN 4 fault state
From Keybox	18EFFF21h	Ext	04 1B 01 05 01 21 FF FF	PIN 5 fault state
From Keybox	18EFFF21h	Ext	04 1B 01 06 01 21 FF FF	PIN 6 fault state
From Keybox	18EFFF21h	Ext	04 1B 01 07 01 21 FF FF	PIN 7 fault state
From Keybox	18EFFF21h	Ext	04 1B 01 08 01 21 FF FF	PIN 8 fault state
From Keybox	18EFFF21h	Ext	04 1B 01 09 01 21 FF FF	PIN 9 fault state
From Keybox	18EFFF21h	Ext	04 1B 01 0A 01 21 FF FF	PIN 10 fault state
From Keybox	18EFFF21h	Ext	04 1B 01 0B 01 21 FF FF	PIN 11 fault state
From Keybox	18EFFF21h	Ext	04 1B 01 0C 01 21 FF FF	PIN 12 fault state
From Keybox	18EFFF21h	Ext	04 1B 01 0D 01 21 FF FF	PIN 13 fault state

## Configuration commands

In this section it is shown a list of control messages to configure the Keybox and/or modify default settings. Where applicable, changes take effect immediately and are stored in non-volatile memory unless otherwise noted.

Note: the request-type messages have 3-bytes data length. (See ISO 11783-3 for further details).

Note 2: for some commands the set values are kept at the startup.

### 15. Read Digital Input 8-bit (0Ah)

The following message sent to the Keybox allows to read the digital input value.

Identifier	18EA2100h	
Byte 0	0Ah	Read digital input 8-bit
Byte 1	00h	Single frame
Byte 2	01h	Enable reading

Answer:

Identifier	18EAF21h	
Byte 0	0Ah	Command byte
Byte 1	00h	Single frame
Byte 2	XXh	06h: command understood (ACK) 15h: command non accepted
Byte 3	P8 P7 P6 P5 P4 P3 P2 P1	'1': digital input
Byte 4	0 0 0 P13 P12 P11 P10 P9	
Byte 5,7	00h	Not used

## 16. Read Fault event (0Bh)

The following message sent to the Keybox allows to read which output pins have gone into the fault condition.

Identifier	18EA2100h	
Byte 0	0Bh	Read Fault event
Byte 1	00h	single frame
Byte 2	01h	Enable reading

Answer:

Identifier	18EAFF21h	
Byte 0	0Bh	Command byte
Byte 1	00h	Single frame
Byte 2	XXh	06h: command understood (ACK) 15h: command non accepted
Byte 3	P8 P7 P6 P5 P4 P3 P2 P1	'1'= fault ; '0'= not in fault
Byte 4	0 0 0 P13 P12 P11 P10 P9	
Byte 5,7	00h	Not used

Examples:

Direction	Identifier	Format	Message	Data
To Keybox	18EA2100h	Ext	0B 00 01	Read enabled
From Keybox	18EAFF21h	Ext	0B 00 06 01 00 00 00 00	PIN 1 in fault
To Keybox	18EA2100h	Ext	0B 00 01	Read enabled
From Keybox	18EAFF21h	Ext	0B 00 06 07 00 00 00 00	PIN 1-2-3 in fault
To Keybox	18EA2100h	Ext	0B 00 01	Read enabled
From Keybox	18EAFF21h	Ext	0B 00 06 00 10 00 00 00	PIN 13 in fault
To Keybox	18EA2100h	Ext	0B 00 01	Read enabled
From Keybox	18EAFF21h	Ext	0B 00 06 80 00 00 00 00	PIN 8 in fault

## 17. Get software revision (2Ah)

Identifier	18EA2100h	
Byte 0	2Ah	Get software revision
Byte 1	00h	single frame
Byte 2	01h	Enable reading

Answer:

Identifier	18EAFF21h	
Byte 0	2Ah	Command byte
Byte 1	00h	Single frame
Byte 2	XXh	06h: command understood (ACK) 15h: command not accepted
Byte 3	XXh	SW revision ASCII
Byte 4	YYh	
Byte 5	WWh	
Byte 6	ZZh	
Byte 7	00h	Not used

Example:

Direction	Identifier	Format	Message	Data
To Keybox	18EA2100h	Ext	2A 00 01	Get software revision
From Keybox	18EAFF21h	Ext	2A 00 06 31 2E 30 35 00	1.05



## 18. Baud rate setting (6Fh)

This message is used to change the baud rate of the CAN bus. Connecting only one Keybox to the bus when changing the baud rate is recommended. If an invalid value is chosen, then no change is done to the stored value.

Byte 0	04h	Header bytes
Byte 1	1Bh	
Byte 2	6Fh	Set baud rate message
Byte 3	02h	500kbit/s
	03h	250kbit/s
Byte 4,7	FFh	Not used

Example:

Direction	Identifier	Format	Message	Data
To Keybox	18EF2100h	Ext	04 1B 6F 02 FF FF FF FF	Set baud rate = 500kbit/s

## 19. Set Source address (70h)

This message is used to change the Keybox CAN source Address and/or the Keybox identifier. Either or both the Source Address or Keybox identifier can be changed independently. Connecting only one device to the bus during the address change is recommended. If an invalid value is chosen, then no change is done to the stored value.

Byte 0	04h	Header bytes
Byte 1	1Bh	
Byte 2	70h	Set address message
Byte 3	XXh	XX: CAN source address From 01h to FDh FEh: reserved FFh: no change
Byte 4	YYh	YY: Keybox identifier From 00h to FDh FEh: reserved FFh no change
Byte 5,7	FFh	Not used

Example:

Direction	Identifier	Format	Message	Data
To Keybox	18EF2100h	Ext	04 1B 70 05 21 FF FF FF	Set source address = 05h Set keybox identifier = 21h

## 20. Periodic fault message transmission (71h)

This command enables or disables the periodic transmission of the fault event message.

When enabled, a message informing if the PIN has entered fault condition is periodically sent for each output of the Keybox.

The period is set to 1s as default value but can be changed by command 77h (see [chapter 24](#) for further details).

Byte 0	04h	Header bytes
Byte 1	1Bh	
Byte 2	71h	Periodic fault event message transmission
Byte 3	XXh	XXh: 00h Disabled (default) 01h Enabled
Byte 4,7	FFh	Not used

Example:

Direction	Identifier	Format	Message	Data
To Keybox	18EF2100h	Ext	04 1B 71 01 FF FF FF FF	Periodic fault event transmission enabled

Keybox reply message:

Byte 0	04h	Header bytes
Byte 1	1Bh	
Byte 2	01h	Fault message
Byte 3	XXh	Pin number (01h-0Dh)
Byte 4	YYh	00h: normal 01h: fault
Byte 5	21h	Keybox identifier
Byte 6,7	FFh	Not used

Example:

Direction	Identifier	Time [s]	Message	Data
From Keybox	18EFFF21h	0.0406	04 1B 01 01 00 21 FF FF	PIN 1 normal state
From Keybox	18EFFF21h	0.0456	04 1B 01 02 01 21 FF FF	PIN 2 fault state
From Keybox	18EFFF21h	0.0506	04 1B 01 03 00 21 FF FF	PIN 3 normal state
From Keybox	18EFFF21h	0.0557	04 1B 01 04 01 21 FF FF	PIN 4 fault state
From Keybox	18EFFF21h	0.0607	04 1B 01 05 00 21 FF FF	PIN 5 normal state
From Keybox	18EFFF21h	0.0656	04 1B 01 06 01 21 FF FF	PIN 6 fault state
From Keybox	18EFFF21h	0.0706	04 1B 01 07 00 21 FF FF	PIN 7 normal state
From Keybox	18EFFF21h	0.0756	04 1B 01 08 01 21 FF FF	PIN 8 fault state
From Keybox	18EFFF21h	0.0806	04 1B 01 09 00 21 FF FF	PIN 9 normal state
From Keybox	18EFFF21h	0.0856	04 1B 01 0A 01 21 FF FF	PIN 10 fault state
From Keybox	18EFFF21h	0.0907	04 1B 01 0B 00 21 FF FF	PIN 11 normal state
From Keybox	18EFFF21h	0.0956	04 1B 01 0C 01 21 FF FF	PIN 12 fault state
From Keybox	18EFFF21h	0.1006	04 1B 01 0D 00 21 FF FF	PIN 13 normal state
From Keybox	18EFFF21h	0.1406	04 1B 01 01 00 21 FF FF	PIN 1 normal state
...	...	...	...	...
...	...	...	...	...

## 21. Fault-event message transmission (72h)

This command enables or disables the transmission of the fault event message (see [chapter 13](#) for further details). This feature is active by default, but if it is disabled when a PIN enters fault condition the Keybox will not transmit the related message.

Byte 0	04h	Header bytes
Byte 1	1Bh	
Byte 2	72h	Fault event transmission
Byte 3	XXh	XX: 00h: Disabled 01h: Enabled (default)
Byte 4,7	FFh	Not used

Example:

Direction	Identifier	Format	Message	Data
To Keybox	18EF2100h	Ext	04 1B 72 00 FF FF FF FF	Fault event transmission disabled

## 22. Heartbeat TX (75h)

This message enables or disables the transmission of Heartbeat message. This message is designed to indicate to other devices on the bus that this unit continues to work.

NOTE: When enabled if it is set a period value out of range, this parameter remains unchanged.

Byte 0	04h	Header bytes
Byte 1	1Bh	
Byte 2	75h	Heartbeat TX
Byte 3	XXh	XX: 00h Disabled (default) 01h Enabled
Byte 4	YYh	YY: Period in milliseconds ÷ 10 From 05h (50ms) to FEh (2.54 sec)
Byte 5,7	FFh	Not used

Example:

Direction	Identifier	Format	Message	Data
To Keybox	18EF2100h	Ext	04 1B 75 01 32 FF FF FF	Set heartbeat message transmission each 500 milliseconds

**Heartbeat TX generated message:**

Byte 0	04h	Header bytes
Byte 1	1Bh	
Byte 2	F9h	Heartbeat message
Byte 3	XXh	XX: Message counter, incremented each message sent
Byte 4	P8 P7 P6 P5 P4 P3 P2 P1	Pin state indicators Each bit represents a PIN state '0': OFF '1': HIGH
Byte 5	0 0 0 P13 P12 P11 P10 P9	
Byte 6	P8 P7 P6 P5 P4 P3 P2 P1	Pin fault state indicators Each bit represents the following states: '1': FAULT '0': NOT FAULT
Byte 7	0 0 0 P13 P12 P11 P10 P9	

Example:

Direction	Identifier	Format	Message	Data
From Keybox	18EFFF21h	Ext	04 1B F9 03 80 00 00 00	Heartbeat message with pin 8 high.
From Keybox	18EFFF21h	Ext	04 1B F9 03 00 10 01 00	Heartbeat message with pin 13 high and pin 1 in fault.

## 23. Heartbeat RX (76h)

This command is used to determine the CAN communication is active by monitoring at a predefined time interval the reception of the heartbeat message from the master device. If for whatever reason this periodic message is not transmitted anymore, the Keybox goes into communication failure and all the outputs will be turned off. The following table details how to set the monitoring time and the CAN master identifier parameters (PRIORITY and PGN). NOTE: the heartbeat RX time should be greater than the related transmission time coming from the producer.

NOTE 2: the command is arranged to receive heartbeat signals transmitted to a specific destination or to all devices connected on the bus (BROADCAST).

Byte 0	04h	Header bytes
Byte 1	1Bh	
Byte 2	76h	Heartbeat RX
Byte 3	RRh	RR: Priority used by the master device 00h-1Fh
Byte 4	SSh	SS: 00h-FFh (PGN value LSByte)
Byte 5	TTh	TT: 00h-FFh (PGN value MSByte)
Byte 6	YYh	YY: Heartbeat RX time in milliseconds LSByte
Byte 7	XXh	XX: Heartbeat RX time in milliseconds MSByte

Heartbeat time: XXYYh (from 000Ah to FEFh: from 10 to 65279 milliseconds).

When the period is set to 0000h, the feature is disabled.

NOTE 3: If it is set a time value out of range, this parameter remains unchanged.

Example 1:

If the master device priority = 0x18h; PGN = 0xEFFDh; PDU SPECIFIC = 0x21h (addressed to the keybox 0x21h); heartbeat message transmitted each 400 milliseconds; then CAN identifier is 0x18EF21FDh and the command should be set as shown in the table below:

Direction	Identifier	Format	Message	Data
To Keybox	18EF2100h	Ext	04 1B 76 18 FD EF F4 01	Monitoring time set to 500 milliseconds
From Master	18EF21FDh	Ext	-	Message transmitted each 400 milliseconds

Example 2:

If the master device priority = 0x1Fh; PGN = 0xAB15h; PDU SPECIFIC = 0xFFh (addressed to all devices - BROADCAST); heartbeat message transmitted each 900 milliseconds; then CAN identifier is 0x1FABFF15h and the command should be set as shown in the table below:

Direction	Identifier	Format	Message	Data
To Keybox	18EF2100h	Ext	04 1B 76 1F 15 AB E8 03	Monitoring time set to 1s
From Master	1FABFF15h	Ext	-	Message transmitted each 900 milliseconds

## 24. Periodic fault message period (77h)

This message sets the period time for the periodic fault event message transmission (see [chapter 20](#) for further details). This does not enable or disable the messages.

Byte 0	04h	Header bytes
Byte 1	1Bh	
Byte 2	77h	Periodic fault event message period
Byte 3	XXh	XX: Period in milliseconds ÷ 10 From 05h (50ms) to FEh (2.54 sec)
Byte 4,7	FFh	Not used

Direction	Identifier	Format	Message	Data
To Keybox	18EF2100h	Ext	04 1B 77 64 FF FF FF FF	Period set to 1 sec

## 25. Restore default parameters (81h)

The following command allows to reset the Keybox to factory settings (see [chapter 10](#) for further details). At the end of this procedure the default parameters will be reactivated.

Byte 0	04h	Header bytes
Byte 1	1Bh	
Byte 2	81h	Restore default parameters message
Byte 3	01h	RESET
Byte 4,7	FFh	Not used

Direction	Identifier	Format	Message	Data
To Keybox	18EF2100h	Ext	04 1B 81 01 FF FF FF FF	Reset Keybox to factory settings

## 26. Set CAN protocol

This set of messages are used to change to the desired CANbus protocol.

- Change from CANopen to J1939:

Direction	Identifier	Format	Message	Data
To Keybox	60Ch	Std	2F FF 20 00 01	Change to J1939

- Change from J1939 to CANopen:

Direction	Identifier	Format	Message	Data
To Keybox	18EF2100h	Ext	04 1B 80 00 FF FF FF FF	Change to CANopen

## 27. Keybox fuse map

FUSE	PIN
FH1	B3
FH2	E1
FH3	F1
FH4	C1
FH5	B1
FH6	A1
FH7	E3
FH8	F3
FH9	A2
FH10	A3
FH11	F2
FH12 (max 3A)	C2
FH13 (max 3A)	D1

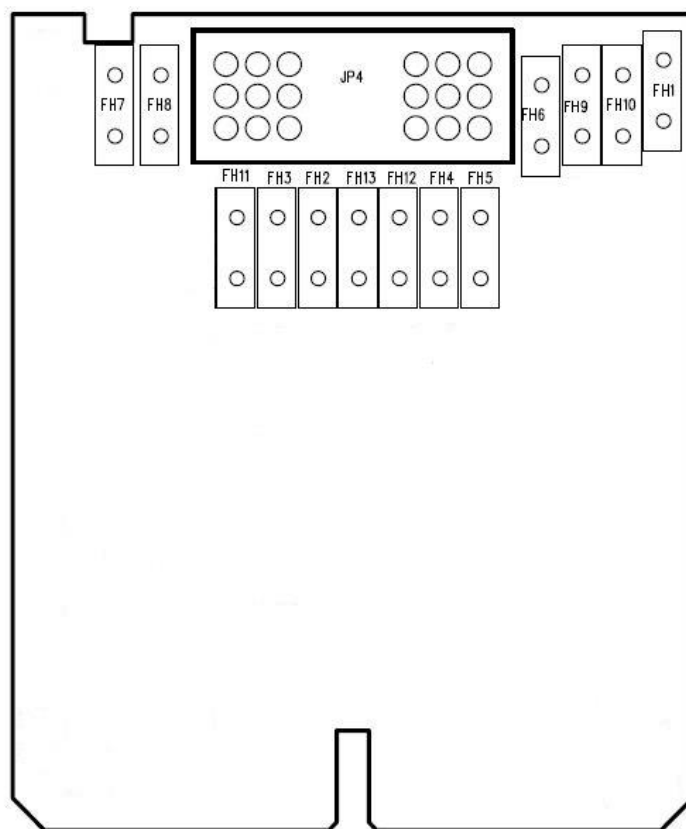



## 28. Revision history

Date	Manual Revision	Comment	Related SW version
01/07/2019	1.0	First release Keybox J1939	Sw x.x
06/08/2019	1.1	Second release Keybox J1939: <ul style="list-style-type: none"><li>• Added Keybox fuse map</li></ul>	Sw x.x
03/11/2019	1.2	Third release Keybox J1939: <ul style="list-style-type: none"><li>• Updated the output state machine diagram</li></ul>	Sw x.x
04/05/2021	1.3	Fourth release Keybox J1939: <ul style="list-style-type: none"><li>• Added NOTE in chapter 1</li><li>• Added NOTE 3 in the chapter 13</li></ul>	Swx.x